

Name:

Date:

CLAD Sample Exam 02

1. You develop a subVI that only outputs a value and need to use this subVI in a (calling) VI. Which of the following is the best way to enforce dataflow to control the execution of the subVI?
 - A. Modify the subVI to have a global variable and use it from the calling VI
 - B. Modify the subVI to have dummy inputs that can be used from the calling VI
 - C. Use the subVI in a sequence structure
 - D. Modify the subVI to have Error clusters that can be used from the calling VI

2. The file c:\data.txt does not exist, but the VI below does not report an error. Which code snippet reports an error and stops?

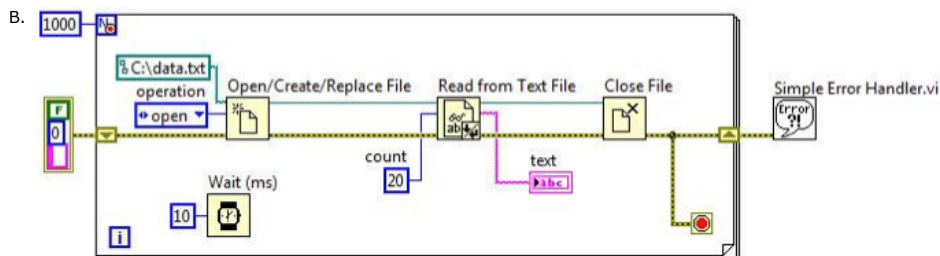
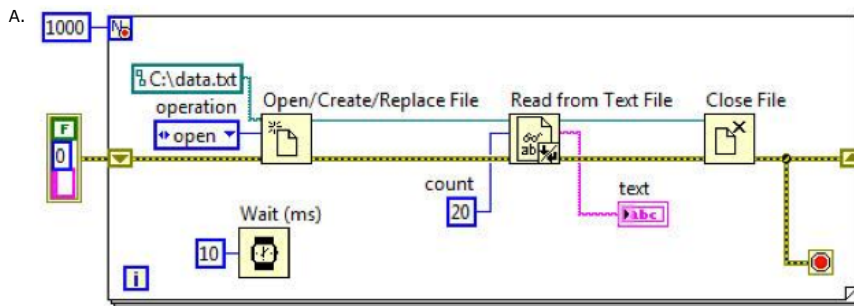
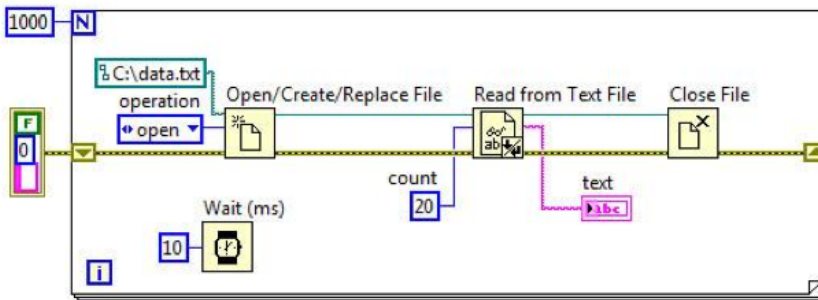

C.

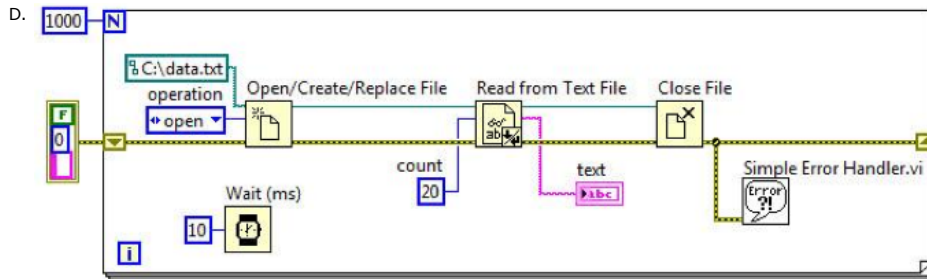
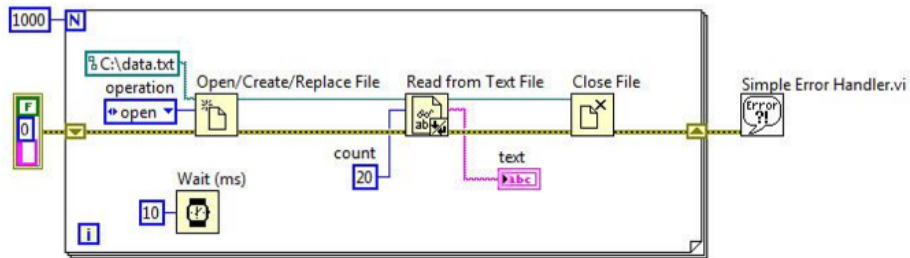

3. Can a wire be used to pass data between loops intended to run in parallel?
 - A. Yes
 - B. No

4. You need to programmatically update the value in a numeric control. Which is the most appropriate strategy?
 - A. Use a Functional Global Variable
 - B. Set the desired value as the default value
 - C. Use a Data Value Reference
 - D. Use a Local Variable

5. Which of the following illustrates an advantage of a global variable over a local variable?
 - A. Only the global variable can pass array data, local variables cannot.
 - B. A global variable can pass data between two independent VIs running simultaneously.
 - C. Global Variables do not require owned labels to operate.
 - D. Global variables do not require owned labels to operate.

6. Which plot will change color first?

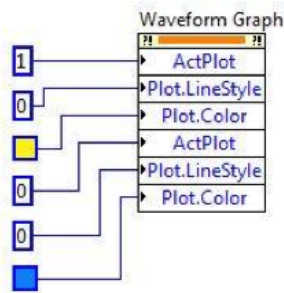

- A. Plot 0 because properties are implemented in numeric order starting at zero.
- B. Plot 1 because properties are executed top-down.
- C. Both plots will be updated simultaneously due to the multithreading of properties.
- D. It cannot be determined because LabVIEW performs operations in dataflow format.
7. Which of the following will allow you to have multiple plots on a Waveform Graph?
- A. Bundle two 1D arrays of X and Y data together for each plot. Then build an array of these clusters and wire it to the Waveform Graph indicator.
- B. Build a 2D array of data with each plot in a separate row (or column) in the array, then wire the array to the Waveform Graph indicator.
- C. Bundle the elements of each waveform into a cluster and build an array of these clusters, then wire the array to the Waveform Graph indicator.
- D. Both B and C.
8. Which statement best describes a Notify event, such as the value change of a Boolean control?
- A. Indication that an event occurred and was discarded by the user.
- B. Indication that an event occurred and LabVIEW did NOT process the event.
- C. Indication that an event did NOT occur but specified Event timeout did occur.
- D. Indication that an event occurred and LabVIEW processed the event.
9. You customize a control, select **Control** from the Type Def. Status pull-down menu, and save the control as a .ctl file. You then use an instance of the custom control on your front panel window. If you open the .ctl file and modify the control, does the control on the front panel window change?
- A. Yes
- B. No
10. How long does this Dequeue Element wait to receive data?

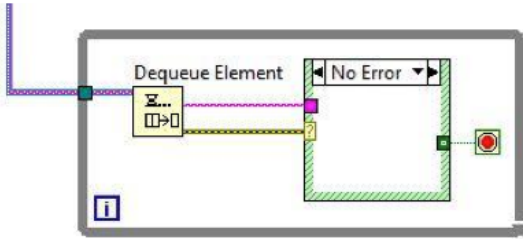

- A. 1 second (default since unwired)
- B. 1 millisecond (default since unwired)
- C. It does not wait, it returns immediately
- D. Indefinitely

11. What value does the **Result F2** indicator display after the VI containing this Stacked Sequence structure executes?

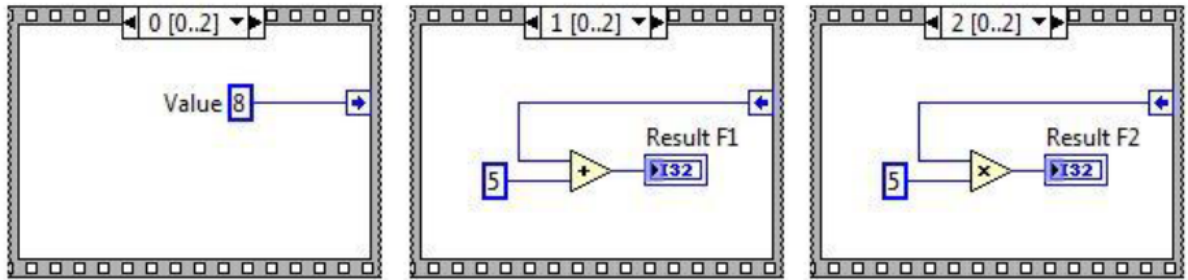

- A. 0
- B. 25
- C. 40
- D. 65

12. Which of the following accurately describes the output that results from the execution of the following loop?

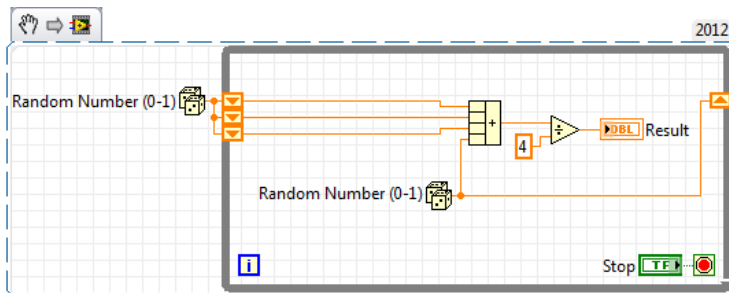

- A. A running average of all Random Numbers will be displayed.
- B. An average of the last 4 Random Numbers will be displayed
- C. The last three values from the Random Number will be displayed.
- D. None of the above.

13. In what instance would you use the Probe tool rather than Highlight Execution?

- A. To see the value of a wire in real time.
- B. To see the flow of data.
- C. To slow down the VI to show the values in wires.
- D. To look into a subVI as the process is running.

14. This graphic displays all the cases of a single case statement. What value does the Result indicator display after the VI executes?

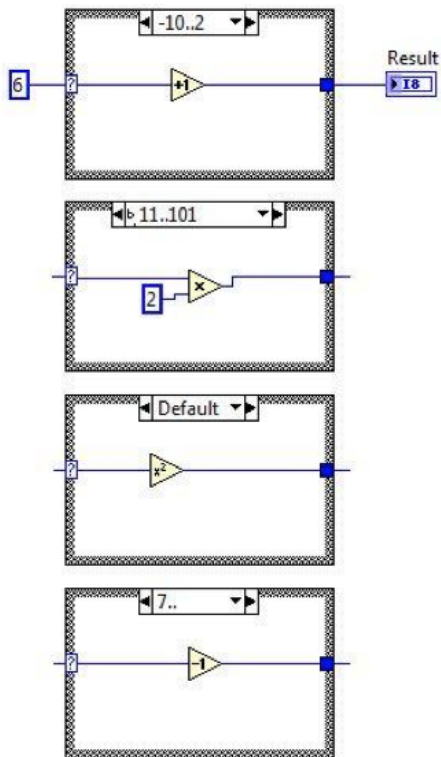

- A. 5
- B. 7
- C. 12
- D. 36

15. The following breakpoint does which of the following?

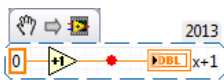

- A. Causes the VI to pause.
- B. Causes the VI to abort.

- C. Causes the VI to single step over the indicator.
- D. Causes the VI to single step over the addition.

16. What value is displayed in **Result** when the code executes?

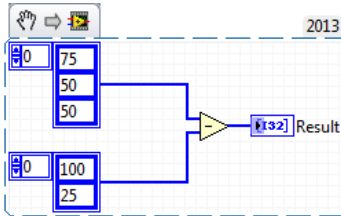

- A. A 1-D Array of {-25, 25, 50}
- B. A 1-D Array of {-25, 25}
- C. A 2-D Array of {{-25, -50, -50}, {50, 25, 25}}
- D. A 1-D Array of {75, -50, 25}

17. Which mechanical action of a Boolean would you use to mimic a button on a Windows dialog?

- A. Switch Until Released
- B. Switch When Released
- C. Latch Until Released
- D. Latch When Released

18. Which is not an important part of creating a Functional Global Variable?

- A. Having a case to handle every action of the Functional Global Variable
- B. Using uninitialized Shift Registers to store information
- C. Setting the While Loop to stop after one execution.
- D. Setting the VI to inline into calling VIs.

19. Which chart update mode should be used to compare old and new data separated by a vertical line? This chart will display similar to an electro-cardiogram (EKG).

- A. Scope Chart
- B. Sweep Chart
- C. Step Chart
- D. Strip Chart

20. The following block diagram represents which common type of VI architecture?

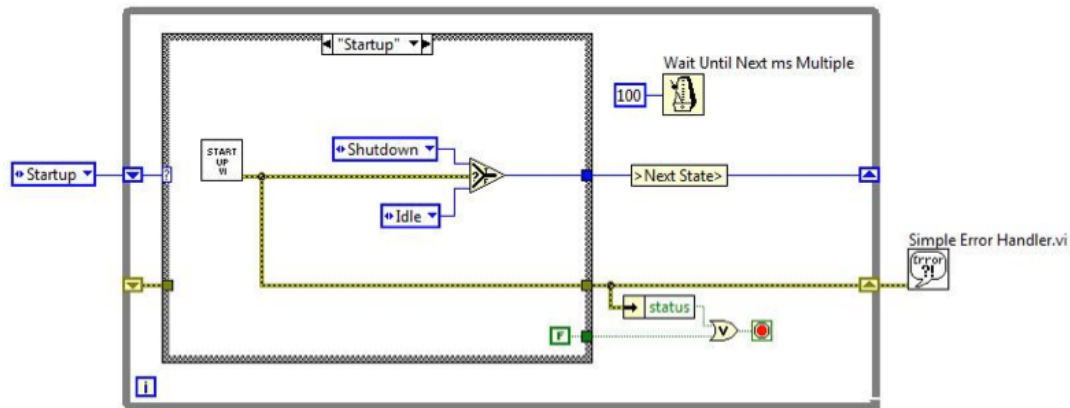

- A. General VI
- B. Multiple Case Structure VI
- C. Parallel Loop VI
- D. State Machine VI

21. The function of a Cluster is to:

- A. Group mixed data types into logical structures.
- B. Present data on the Front Panel using Charts or Graphs.
- C. Provide a means of differentiating between data types on the Block Diagram.
- D. Separate data object by data type on the Front Panel.

22. A coercion dot indicates that:

- A. A polymorphic operation will be performed on the data.
- B. A data buffer will be created to handle the data conversion.
- C. Data values are being coerced because they are out of range.
- D. The data types are consistent.

23. Which combination of words correctly completes the following statement?

Unlike _____ Property Nodes, _____ Property Nodes require _____ as inputs in order to function correctly.

- A. Explicit; Implicit; Data Value References
- B. Implicit; Explicit; Data Value References
- C. Explicit; Implicit; Control References
- D. Implicit; Explicit; Control References









24. What is one disadvantage of using the State Machine VI architecture?

- A. The diagram becomes significantly larger when changing from a general architecture to a State Machine.
- B. State Machines cannot acquire data or use DAQ functions.

- C. A State Machine can only traverse states in order.
- D. If two state changes occur at the same time, only the first state change will be handled and the second will be lost.

25. Which combination of words correctly completes the following statement?

The _____ indicates the total number of times the loop will execute and the _____ returns the number of times the loop has executed minus one.

- A. conditional terminal,  ; count terminal, .
- B. count terminal,  ; iteration terminal, .
- C. conditional terminal,  ; iteration terminal, .
- D. count terminal,  ; conditional terminal, .

26. Which statement best describes a LabVIEW Project (.lvproj) file?

- A. A compiled version of code mostly used for final deployment of an application.
- B. A file that contains references to, and provides organization for all files pertaining to an application.
- C. A specialized folder that contains all files pertaining to an application.
- D. A file containing a front panel and block diagram where programming steps can be implemented.

27. Which of the following statements is **TRUE** regarding the execution of the following code?

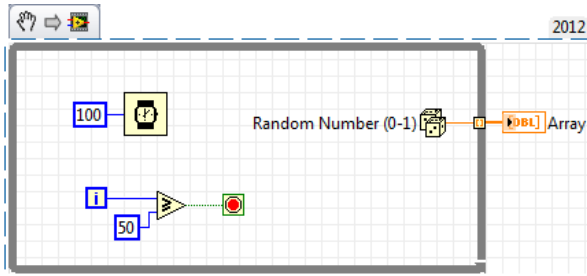

- A. The loop will iterate 49 times.
- B. The loop will iterate 50 times.
- C. The loop will iterate 51 times.
- D. A For Loop that has a 50 wired to the count terminal will perform the same operation.

28. Which of the following will cause an event to be captured by the LabVIEW Event Structure?

- A. Changing a value on a Front Panel control via a mouse click.
- B. Programmatic update of a Front Panel control via a control reference.
- C. Update of a Front Panel control using a property node.

D. Using VI Server to update a Front Panel control.

29. What value does the **Result** indicator display after the code snippet executes?

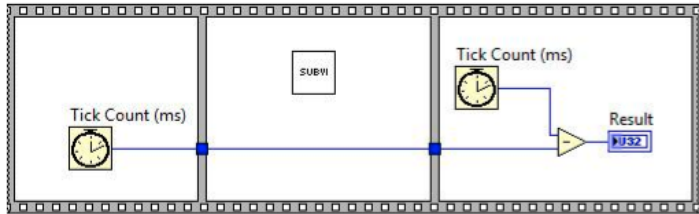

- A. Zero
- B. The time elapsed in milliseconds during the execution of SubVI.
- C. The number of seconds elapsed since January 1, 1970
- D. The time elapsed in milliseconds during the execution of the sequence structure



30. You have a control on the front panel of a VI and you need to modify one of its properties at run time. Which of the following is the best approach you would take?

- A. Create a local variable and select the property to modify
- B. Create a linked shared variable and select the property to modify
- C. Create an implicit property node and select the property to modify
- D. Create a control reference, pass the reference to a property node and select the property to modify

31. The most efficient method for creating an array is:

- A. Initializing the array and then replacing elements in a while loop.
- B. Using a For Loop with Auto-Indexing.
- C. Placing a Build Array function in a while loop.
- D. Using a While Loop with Auto-Indexing.

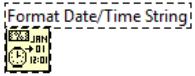
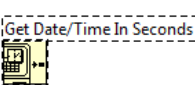
32. Which timing function (VI) is the best choice for timing control logic in applications that run for extended periods of time?

- A.  Format Date/Time String
- B.  Get Date/Time In Seconds
- C.  Wait (ms)
- D. 

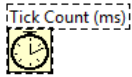

33. For the VI shown in the following block diagram, automatic error handling is enabled. If the file c:\data.txt does not exist, will an error dialog box pop up?

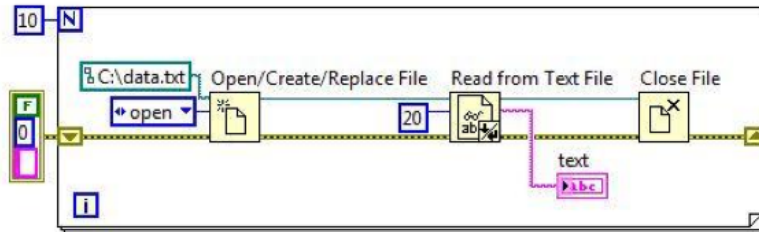

- A. Yes, each time a loop iteration completes.
- B. Yes, each time the error from the Open/Create/Replace File function is returned.
- C. Yes, but only once, not on each iteration of the loop.
- D. No

34. If an input name on the Show Context Help window is in bold for a subVI, which of the following conditions are true? **(Multiple Answers may apply)**

- A. An input is recommended, but not required.
- B. A broken run arrow will result unless the input is wired.
- C. Input values must be scalar.
- D. An input is required.

35. In the figure below, the output of **Array Size** is:

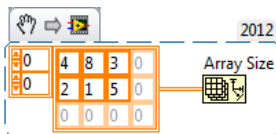

- A. 2
- B. 1D Array of {2, 3}
- C. 1D Array of {3, 2}
- D. None of the above.

36. Which snippet writes the smallest amount of data to disk?

- A.

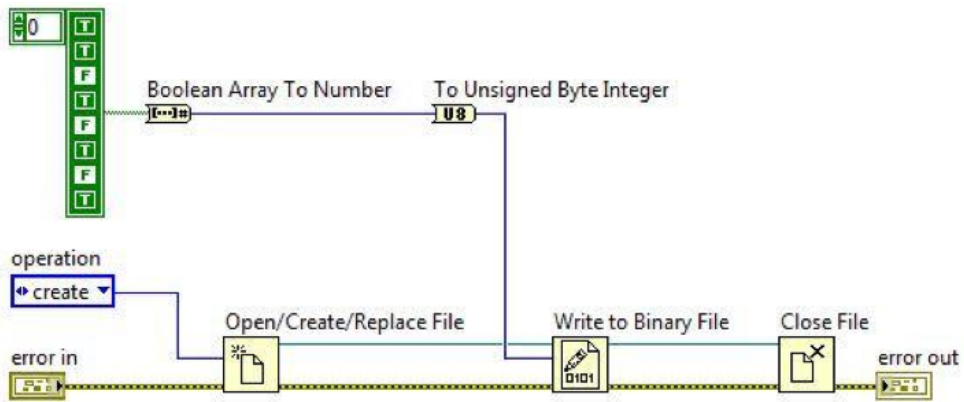

B.

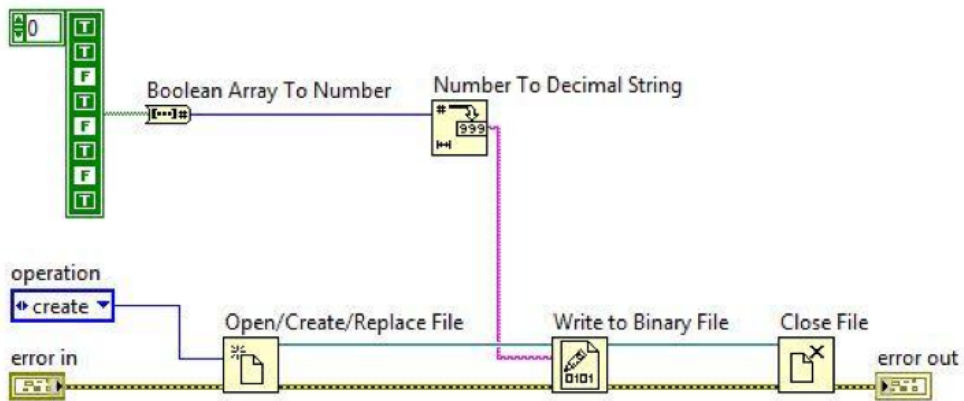

C.

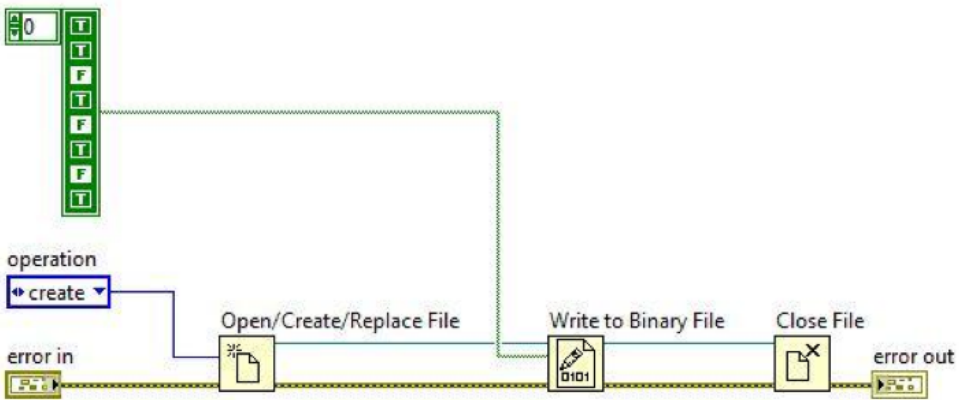

D.

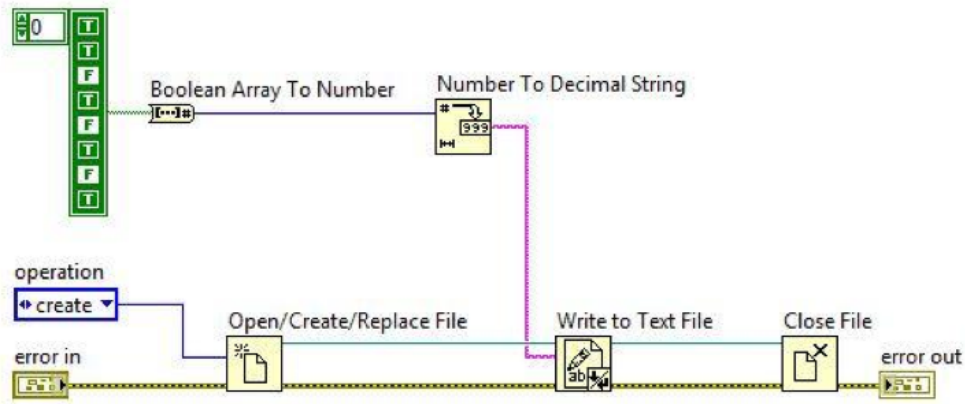

37. Which setting assigns specific keys or key combinations to a front panel control?

- A. Key Navigation
- B. Key Focus
- C. Distribute Objects
- D. Radix

38. What is the result in **new string** after the following code has executed?

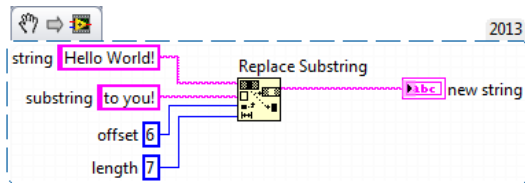

- A. Helloto you!
- B. Hello to you!!
- C. Hello Two you!
- D. Hello to you!

39. What functionality do Control References provide?

- A. Control of multiple DAQ inputs through alias names.
- B. Ability to wire from controls to functions and subVIs.
- C. Ability to add controls and indicators to a VI programmatically.
- D. Access to the properties of Front Panel objects in subVIs.

40. What value does the **Numeric** indicator display after this code executes?

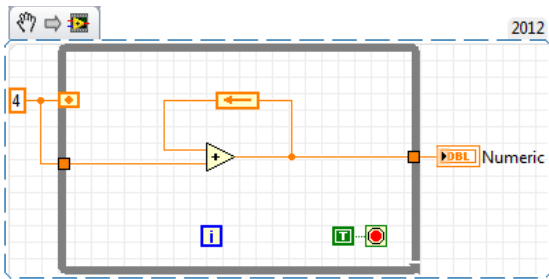

- A. 0
- B. 4
- C. 8
- D. The While Loop iterates indefinitely.